

JOB NAME _____
 TYPE _____

LBQ ICE-ETRONIC LOW BAY LUMINAIRE
 150 watt ICETRON® LAMP

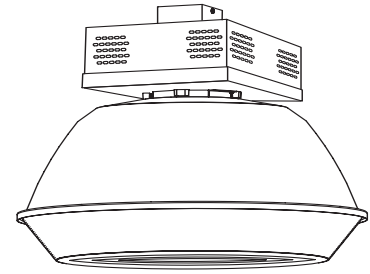

The LBQ Ice-Etronic Low Bay Luminaire is designed for use in gymnasiums, warehouses, educational, retail and commercial applications, where the 100,000 hour lamp life will reduce high maintenance costs.

ORDERING MATRIX

SAMPLE CATALOG NUMBER: LBQ21.50E-U-LR28CF

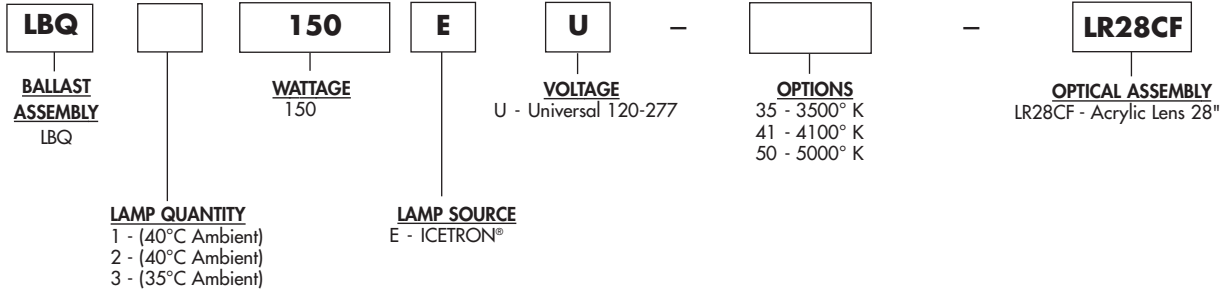

ACCESSORIES (ORDER SEPARATELY)

- CH - Cover Half for Power Hook (use with PB)
- PB - Power Box for Power Hook (use with CH)
- HP12 - Hook-Cord-Plug Assembly 120V
- HP25 - Hook-Cord-Plug Assembly 208-240V
- HP27 - Hook-Cord-Plug Assembly 277V
- HMR - Suspension Hook Male
- LMR - Suspension Loop Male
- WGLR28 - Wire Guard

General Notes:
 All accessories are field installed.
 All options factory installed.

CSA/CUS Certified.

(Refer to Section 18000 for additional accessories.)

DIMENSIONS

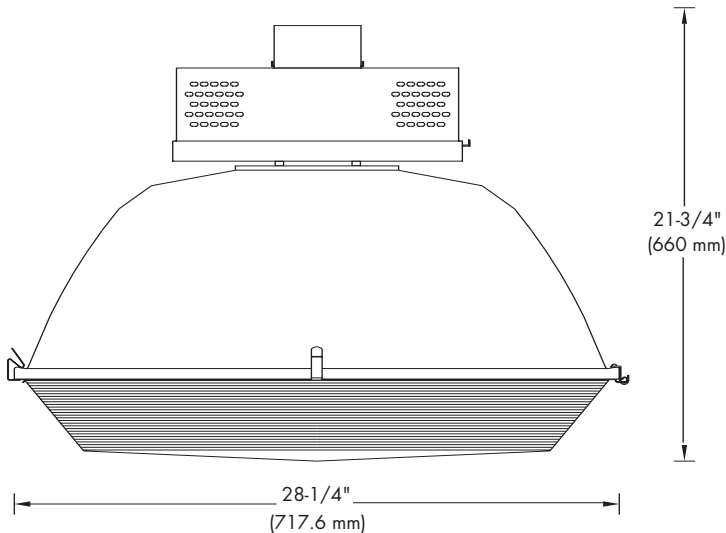



- Long 100,000 hour life
- White Light - 3500K, 4100K and 5000K
- Consistant colour - 80CRI
- Instant on - instant restrike
- High output electronic system
- Universal voltage ballast
- Starting temperatures as low as -40°F

Ballast Specification
 Lamp Frequency: 200-300 KHz
 Input Frequency: 50/60Hz
 Voltage Range: 120 to 277 ± 10%
 UL Listed Class P, Type 1 Outdoor CSA Certification
 Lamp CCF: Less than 1.7
 Low THD: Less than 15%
 158°F (70°C) Maximum Temperature for QT1X150ICE/UNV-T at test point Tc on ballast label
 149°F (65°C) Maximum Temperature for QT1X100ICE/UNV-T at test point Tc on ballast label
 Class A Sound Rating
 Starting Temperature -40°F (-40°C) minimum (ICE70 lamps on QT1X100ICE/UNV-T) -13°F (-25°C) minimum
 Power Factor: Greater than 95%
 FCC 47CFR Part 18 Non-Consumer
 ANSI 62.41 Cat. A Transient Protection
 Ballast Dimension: 7.15" L x 3.96" W x 1.70" overall

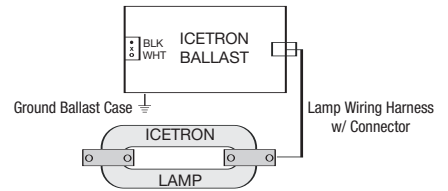

LAMP COMPARISON

	System Watts	Initial System Lumens ¹	System LPW	System Lumens @10,000 hours	Life (hrs) 10 hrs/start	CRI
ICETRON 70	79	6500	82	5545	100,000	80
70W Metal Halide	90	5200	58	3400	15,000	75
2 FBO31/800XP	57	5160	91	4850	26,000	85
ICETRON 100	106	8000	75	6825	100,000	80
100W Metal Halide	129	8500	66	5500	15,000	75
3 FBO31/800XP	84	7740	92	7275	26,000	85
ICETRON 150	161	12,000	75	10,235	100,000	80
150W Metal Halide	185	12,900	70	8400	15,000	75

1. Lumen data for 3500K and 4100K; lumens for 5000K will be slightly lower.

TECHNICAL INFORMATION

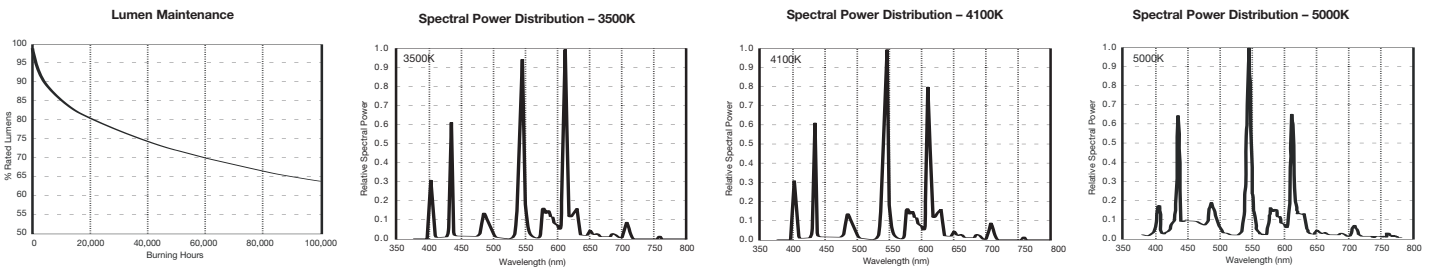

PRODUCT FEATURES

CSA/CUS Certified 40°C ambient for one and two lamps and 35°C for three lamps.

1. Die cast 3/4" hub for easy, positive mounting.
2. Mounting/wiring box with 1/2" and 3/4" concentric knockouts for thru-wire conduit connections.
3. Heavy wall fabricated aluminum housing with white polyester powder finish.
4. 1-Lamp electronic ballasts.
5. Precision spun heavy gauge aluminum reflector coated inside and out with highly reflective (90-92%) white polyester powder finish.
6. One piece injection molded 100% virgin acrylic lens hinged and latched to the reflector for easy of installation and maintenance.

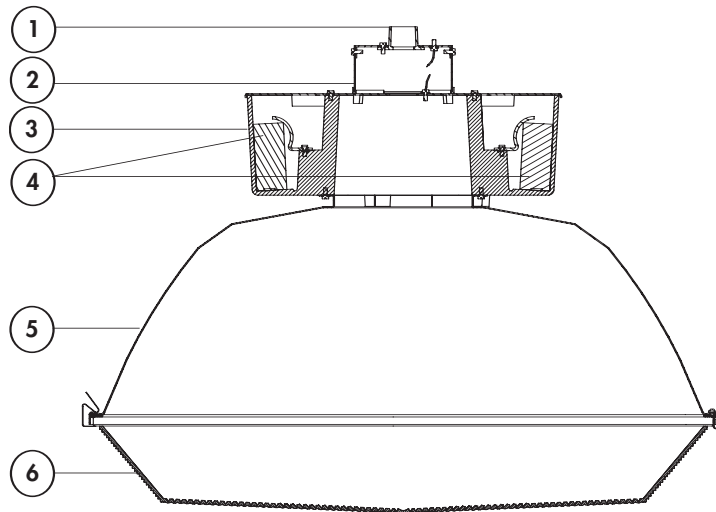

Visit our web site at www.daybritelighting.com

LB-11055

776 South Green Street Tupelo, MS 38804 Phone: 662-842-7212 Fax: 662-841-5501

189 Bullock Drive Markham, Ontario Canada L3P 1W4 Phone: 905-294-9570 Fax: 905-294-8911
 Day-Brite Lighting reserves the right to make changes without notice. ©April 2007. DL0407
 Day-Brite Lighting is a Genlyte Thomas Group.

Day-Brite® Lighting
 a Genlyte company